



OUTDOOR STORAGE

MODEL N° 60021

OWNER'S MANUAL

COPY

Keep this Identification Number in case you must contact our Customer Service Department.

REGISTER YOUR LIFETIME PRODUCT TODAY!

There are benefits to registering your Lifetime product. With our new online product registration form, it's fast and easy! Register with us at www.lifetime.com and enjoy these great benefits:

- Receive exclusive money-saving offers from BuyLifetime.com, our online store, as well as NEW product notifications and special closeout promotions!
- In the unlikely event of a product recall or safety modification, we will notify you.
- Registering your product guarantees you warranty service. If you do not register your product, your warranty rights will not be diminished. But you will need to provide a sales receipt to verify your product purchase date before warranty service will be provided.

LIFETIME'S PROMISE TO YOU:

Maintaining your privacy is our long-standing policy at Lifetime. And you can rest assured that Lifetime will not sell or provide your personal data to other third parties, or allow them to use your personal data for their own purposes.

We invite you to read our privacy policy at www.lifetime.com

REGISTER today!

****U.S. and Canada customers ONLY****

IF ASSISTANCE IS NEEDED,

DO NOT CONTACT THE STORE!

CALL OUR CUSTOMER SERVICE DEPARTMENT at 1 (800) 225-3865

HOURS: 7:00 a.m. to 5:00 p.m. Monday through Friday (Mountain Standard Time)

Call or visit our Web site for Saturday hours

Lifetime Products, Inc.

PO Box 160010 • Freeport Center, Bldg. D-11 Clearfield, Utah 84016-0010

For customers outside the U.S. or Canada, please contact the store for assistance.



SAFETY INSTRUCTIONS



FAILURE TO FOLLOW THESE WARNINGS MAY RESULT IN SERIOUS INJURY OR PROPERTY DAMAGE AND WILL VOID WARRANTY.

To ensure safety, do not attempt to assemble this product without reading and following all instructions carefully. Check the entire box and inside all packing materials for parts and/or additional instruction material. Before beginning assembly, identify and inventory all parts and hardware using the parts and hardware lists and identifiers in this document. Proper and complete assembly, use and supervision are essential for proper orientation and to reduce the risk of accident or injury. A high probability of serious injury exists if this product is not installed, maintained, and/or operated properly. Failure to comply with any of the warnings in this instruction manual may result in serious personal injuries such as cuts, broken bones, nerve damage, paralysis, brain injury, or death. Failure to comply may also result in property damage. Please heed all warnings and cautions.

- Two capable adults are required for assembly.

Most injuries are caused by misuse and/or not following instructions. Use caution when using this product.

BEFORE BEGINNING ASSEMBLY



Keep the hardware bags and their contents separate. If any parts are missing, call our Customer Service Department.

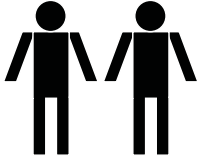

****Two adults required to complete assembly****

Only adults should set up the product. Do not allow children in the set-up area until assembly is complete.



TOOLS AND PARTS REQUIRED FOR THIS ASSEMBLY

3/4"



(1)

7/16"



(1)

Power Drill

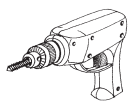

(1)

Socket Wrench
with 3/4" & 1/2" Sockets



(1)

#2 Phillips
Screwdriver



(1)

1/8" Drill Bit
(Included)



(1)

Safety Glasses



(1 for each person)

Refer to the following areas throughout the instructions to assist in the assembly process:

This area is located at the top, left-hand corner of the page and indicates which tools and hardware are needed to complete the assembly steps on a page.



TOOLS AND HARDWARE REQUIRED FOR THIS PAGE

This area is located at the top, right-hand corner of the page and shows an image of the product with shaded parts indicating which section is being assembled.



This area is usually located in the bottom, left-hand corner of a step and indicates that special attention is needed to perform a particular part of a step.



Note:

These areas are usually located in the bottom, right-hand corner of a step and indicate that damage to the product or serious injury may occur if the caution or warning is not heeded.



CAUTION



WARNING

PARTS & HARDWARE LIST

BOX 1

MAIN COMPOSTER PARTS

ID	Description	Qty
BHN	Front Panel/Lid	3
BHM	End Panel	2
BII	A-Frame Weldment	2
BIH	Composter Leg	2
BHQ	Ventilation Tube	1
BSA	Mounting End Plate	2
BSB COMPOSTER SMALL PARTS BAG		
BIX	Locking Pin Assembly	1
BIY	Pinned Hinge	2
BIZ	Latch Hook	2
BJA	Latch Assembly	2
BJB	Hinge Tube	2
BJC	Double Hook Strap	2

ID	Description	Qty
BJJ HARDWARE BAG		
BTL COMPOSTER TUMBLER ASSEMBLY HARDWARE		
BHO	5/16" Steel Flat Washer	6
AAN	5/16" Cap Nut	6
BTK	Blow Hole Plug	6
BIR	5/16" x 3/4" Carriage Bolt	6
BHK	Plastic Nut	40
ADW	#10 x 3/4" Phillips Pan-Head Screw	40
ARA	1/8" Drill Bit	1
BIT COMPOSTER BASE ASSEMBLY HARDWARE		
BIJ	Inner Housing Bracket	2
ADM	1/2" Nylock Nut	2
BIK	1/2" x 2 3/4" Hex-Head Bolt	2
BIL	Sleeve	2
BIM	Black Plastic Spacer	2
BIN	Locking Pin Spring	1
BIO	1/2" Flat Washer	4
BIP	5/8" Flat Washer	2
AKH	Grease Packet	1
BHJ	#8 x 1/2" Self-Tapping Screw	4

PARTS IDENTIFIER

Main Composter Parts

Parts are shown 10% of actual size

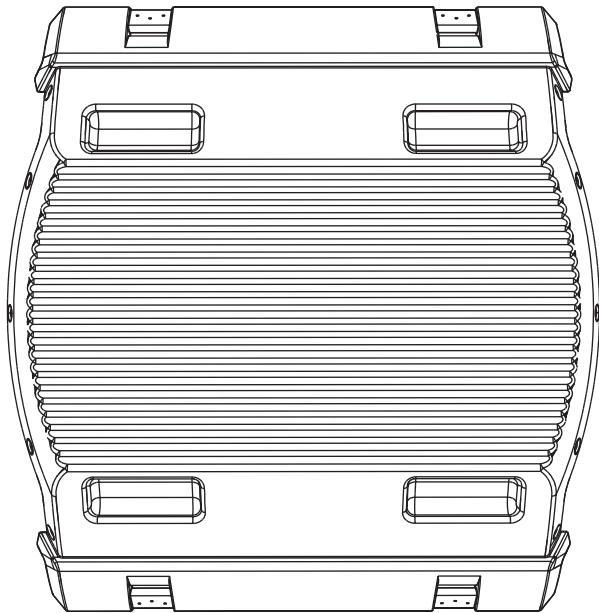

BHN (x3)
Front Panel/Lid

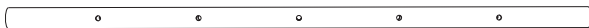

BHQ (x1)
Ventilation Tube

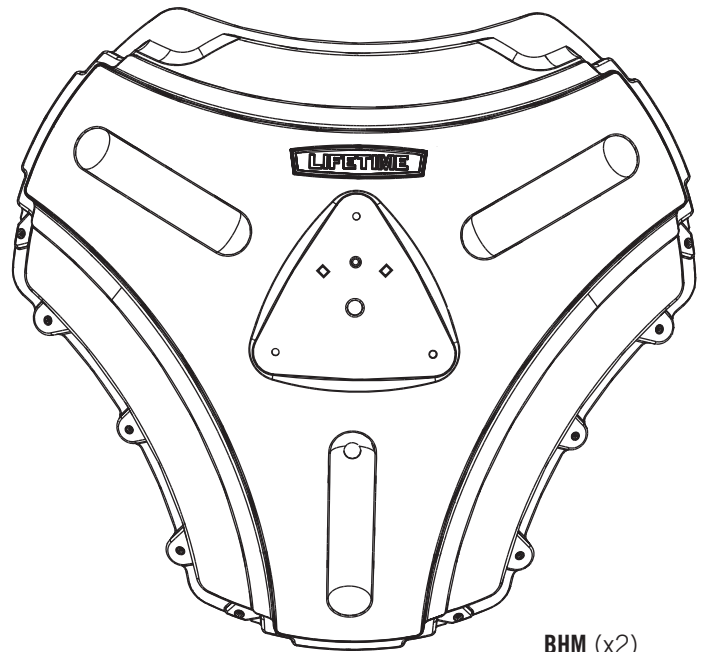

BHM (x2)
End Panel

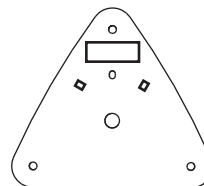

BSA (x2)
Mounting End Plate*
(1 with a Warning Sticker
and 1 without)

PARTS IDENTIFIER

Main Composter Parts

Parts are shown 5% of actual size

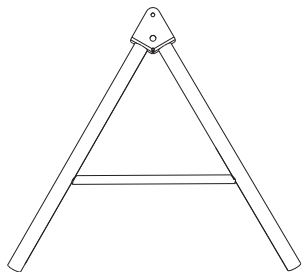

BII (x2)
A-Frame Weldment

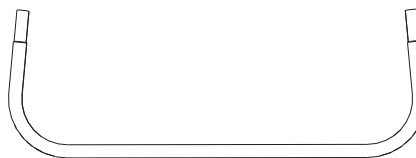

BIH (x2)
Composter Leg

Composter Small Parts Bag [BSB]

Parts are shown 50% of actual size (Unless indicated otherwise*)

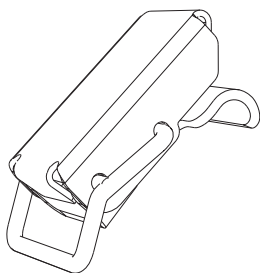

BJA (x2)
Latch Assembly

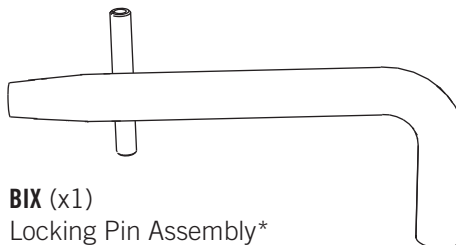

BIX (x1)
Locking Pin Assembly*

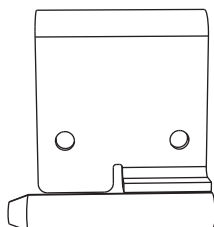

BIY (x2)
Pinned Hinge

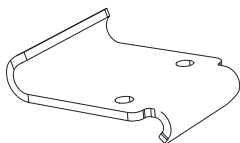

BIZ (x2)
Latch Hook

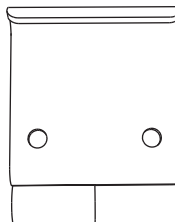

BJB (x2)
Hinge Tube

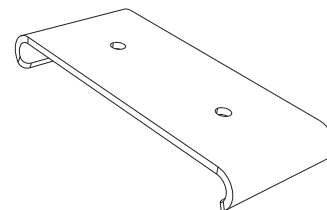

BJC (x2)
Double Hook Strap



WARNING

Only use the Locking Pin to hold the Tumbler in place. Do not use the Locking Pin to stop a spinning Tumbler. Failure to heed this warning will result in damage to the Locking Pin.

HARDWARE IDENTIFIER

Composter Tumbler Assembly Hardware [BTL]

Hardware is shown at actual size

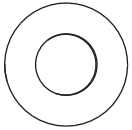

BHO (x6)
5/16" Steel Flat Washer

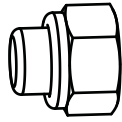

AAN (x6)
5/16" Cap Nut

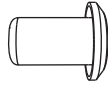

BTK (x6)
Blow Hole Plug

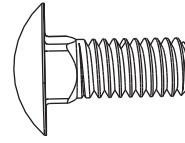

BIR (x6)
5/16" x 3/4" Carriage Bolt

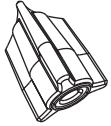

BHK (x40)
Plastic Nut
(Only 38 are used)

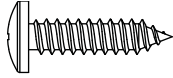

ADW (x40)
#10 x 3/4" Phillips Pan-Head Screw
(Only 38 are used)



ARA (x1)
1/8" Drill Bit

Composter Base Assembly Hardware [BIT]

Hardware is shown at actual size (Unless indicated otherwise*)

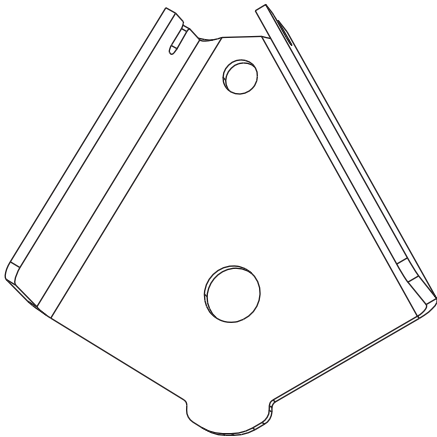

BIJ (x2)
Inner Housing Bracket*

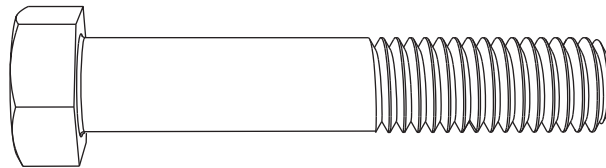

BIK (x2)
1/2" x 2 3/4" Hex-Head Bolt

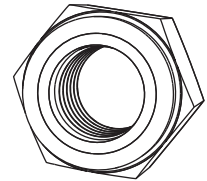

ADM (x2)
1/2" Nylock Nut

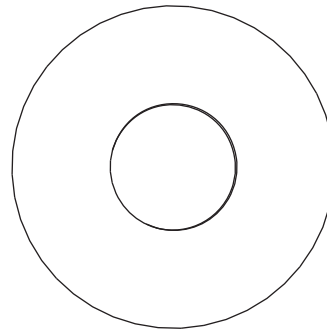

BIP (x2)
5/8" Flat Washer

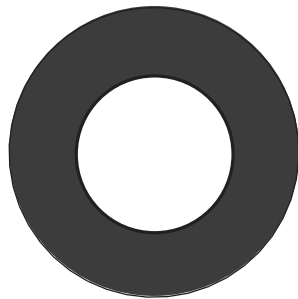

BIM (x2)
Black Plastic Spacer



BIN (x1)
Locking Pin Spring

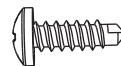

BHJ (x4)
#8 x 1/2" Self-Tapping Screw

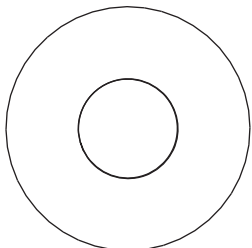

BIO (x4)
1/2" Flat Washer

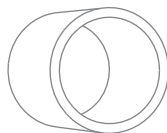

BIL (x2)
Sleeve

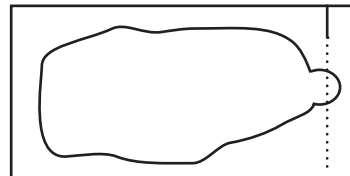

AKH (x1)
Grease Packet

SEC 1 TUMBLER ASSEMBLY

HARDWARE REQUIRED

Hardware is shown at actual size

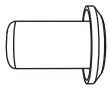

BTK (x6)
Blow Hole Plug

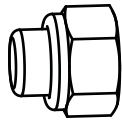

AAN (x6)
5/16" Cap Nut

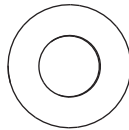

BHO (x6)
5/16" Steel Flat Washer

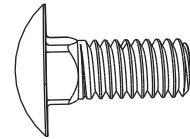

BIR (x6)
5/16" x 3/4" Carriage Bolt

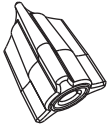

BHK (x40)
Plastic Nut
(Only 38 are used)

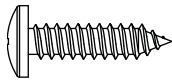

ADW (x40)
#10 x 3/4" Phillips Pan-Head Screw
(Only 38 are used)



ARA (x1)
1/8" Drill Bit

SMALL PARTS REQUIRED

Parts are shown 50% of actual size (Unless indicated otherwise*)

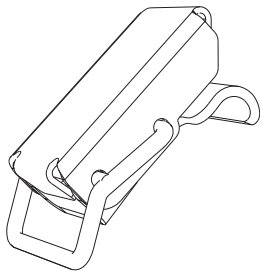

BJA (x2)
Latch Assembly

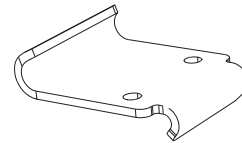

BIZ (x2)
Latch Hook

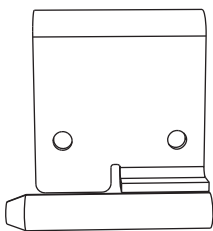

BIY (x2)
Pinned Hinge

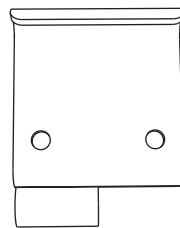

BJB (x2)
Hinge Tube

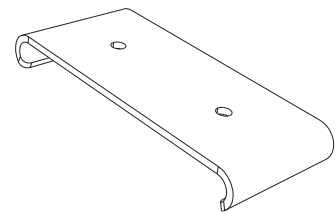

BJC (x2)
Double Hook Strap

SEC. 1 TUMBLER ASSEMBLY (CONT.)

PARTS REQUIRED (CONT.)

Parts are shown 10% of actual size

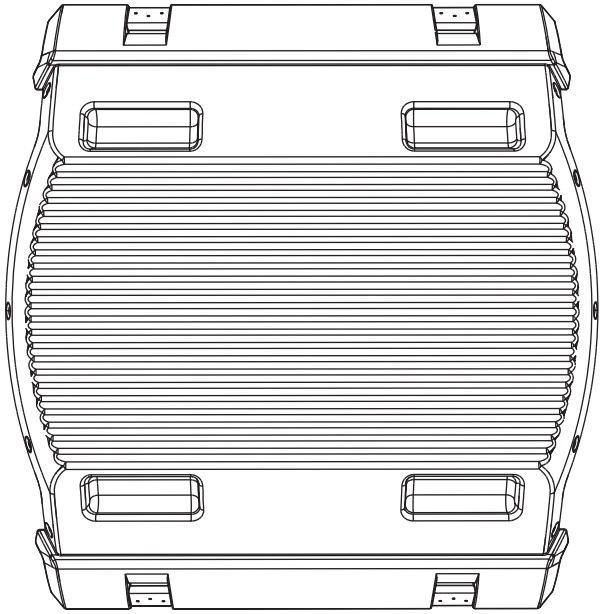

BHN (x3)
Front Panel/Lid



BHM (x2)
End Panel

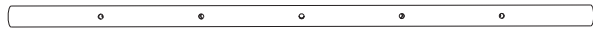

BHQ (x1)
Ventilation Tube

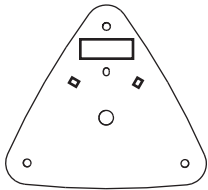

BSA (x2)
Mounting End Plate*
(1 with a Warning Sticker and 1 without)

TOOLS REQUIRED

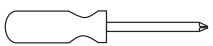

Phillips Screwdriver



Socket Wrench with 1/2" Socket

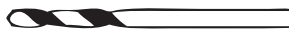

1/8" Drill Bit (ARA) (Included)



Electric Drill w/Phillips Head

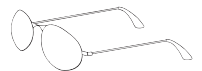

Safety Glasses

1.



TOOLS AND HARDWARE REQUIRED FOR THIS PAGE

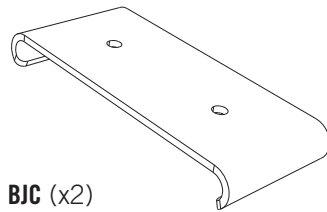

BJC (x2)

SEC 1

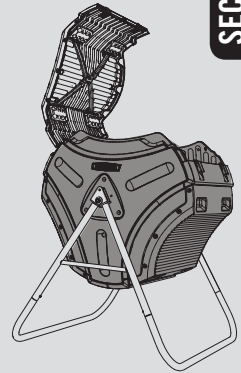

SEC

TUMBLER ASSEMBLY

1.1

Insert two **Double Hook Straps (BJC)** into the grooves on the end of one of the **Front Panels (BHN)** as shown.

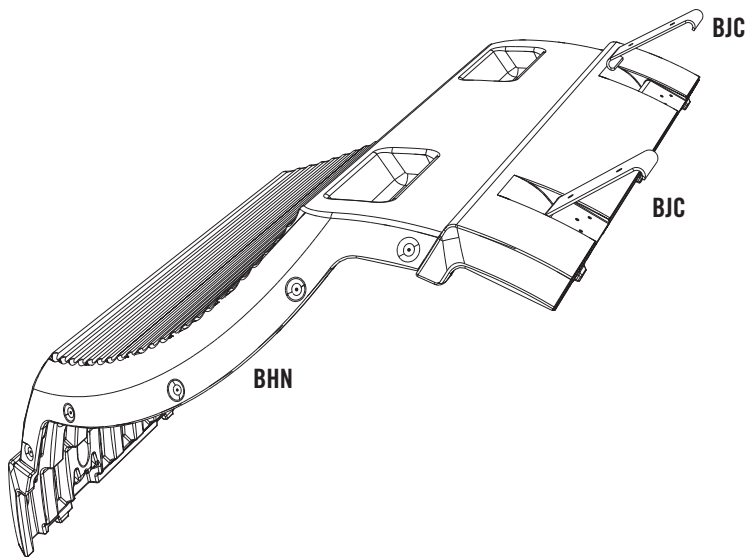

SEC

1.2

Insert the ends of the Double Hook Straps into the grooves of another Front Panel as shown and align the edges.

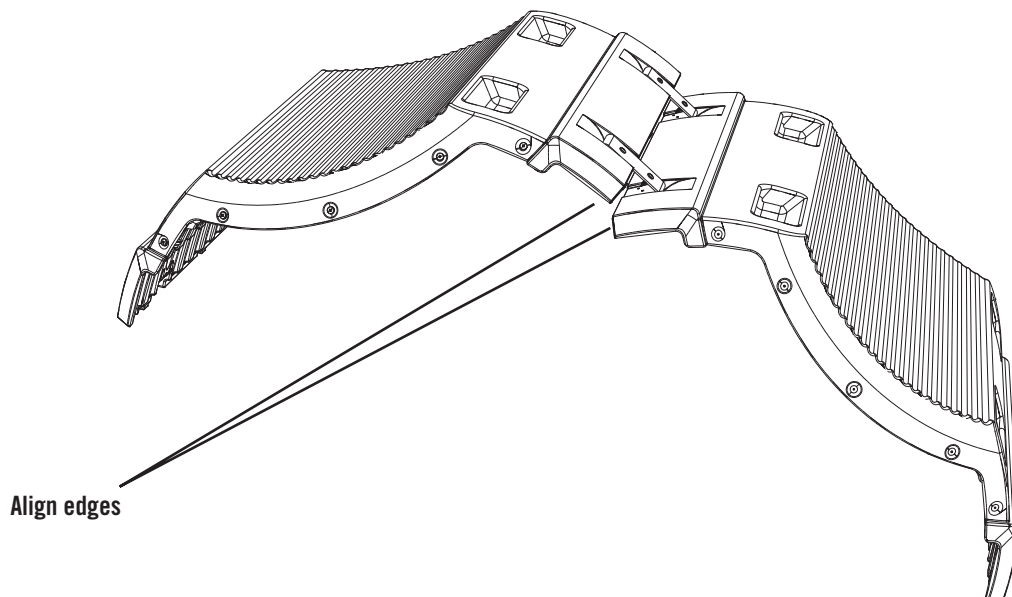



TOOLS AND HARDWARE REQUIRED FOR THIS PAGE

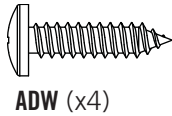
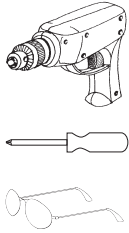

ADW (x4)

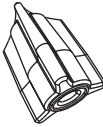

BHK (x4)



ARA (x1)

SEC 1

1.

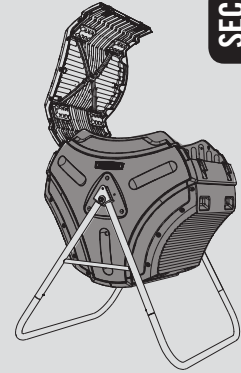

SEC

1.3

Pull the Front Panels down to the position shown.

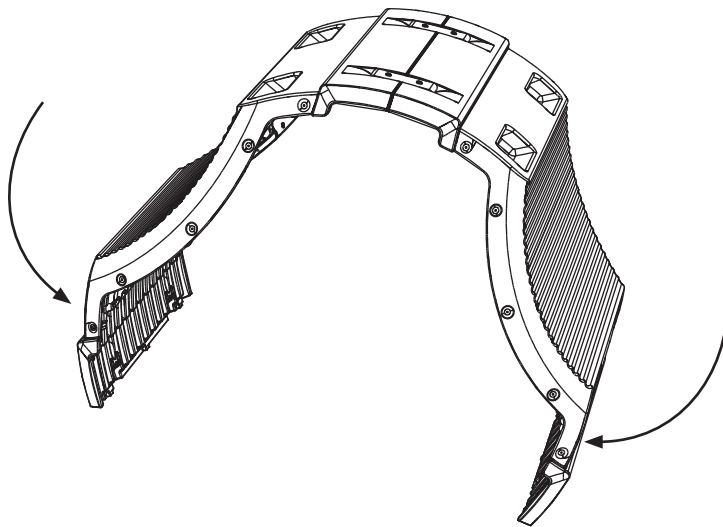

SEC

1.4

Using the 1/8" Drill Bit (ARA), drill four (4) 1/8" holes through the holes in both Double Hook Straps and all the way through the two Front Panels. Using a screwdriver, manually screw four (4) #10 x 3/4" Phillips Pan-Head Screws (ADW) through the holes you just drilled and into the Plastic Nuts (BHK) until the Nuts are flush against the Panels. Do not overtighten.

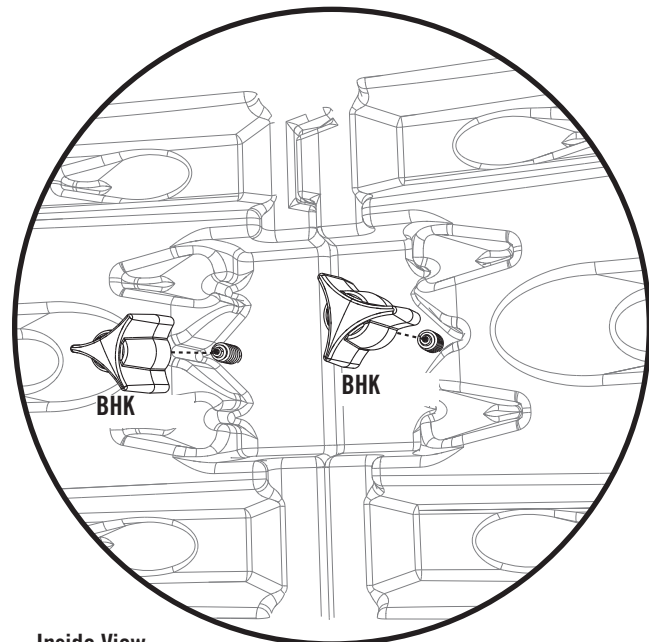
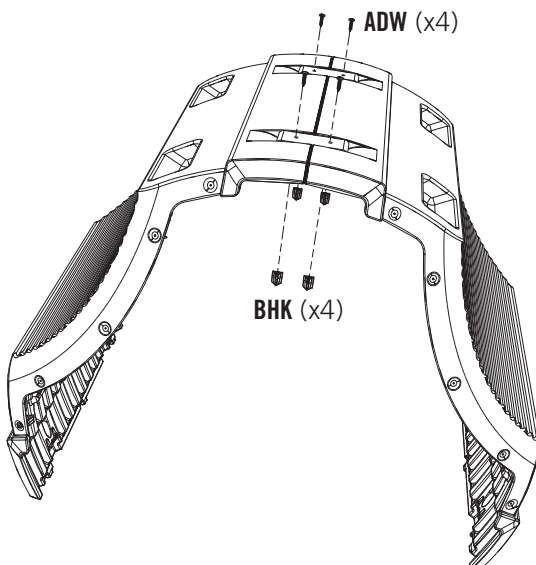

Inside View

1.



TOOLS AND HARDWARE REQUIRED FOR THIS PAGE

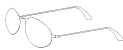
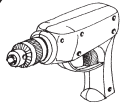

ARA (x1)

SEC 1

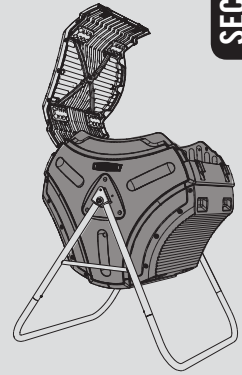

SEC

1.5

2 ADULTS REQUIRED FOR THIS STEP

While one adult holds the Panels in place, use the 1/8" Drill Bit (ARA) to drill ten (10) 1/8" holes through the divots in the Panels. Repeat this step for the opposite end of the Panels.

Drill holes at these locations

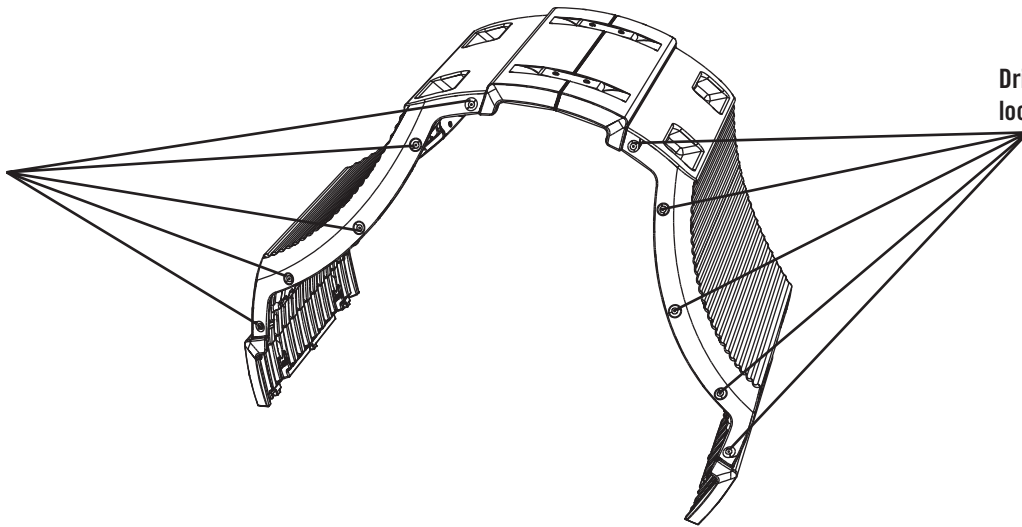

Drill holes at these locations

SEC

1.6

2 ADULTS REQUIRED FOR THIS STEP

While one adult holds the two Front Panels in place, slide an End Panel (BHM) down in between the Front Panel Assembly as shown.

The Ventilation Hole for the Ventilation Tube should be facing downward.

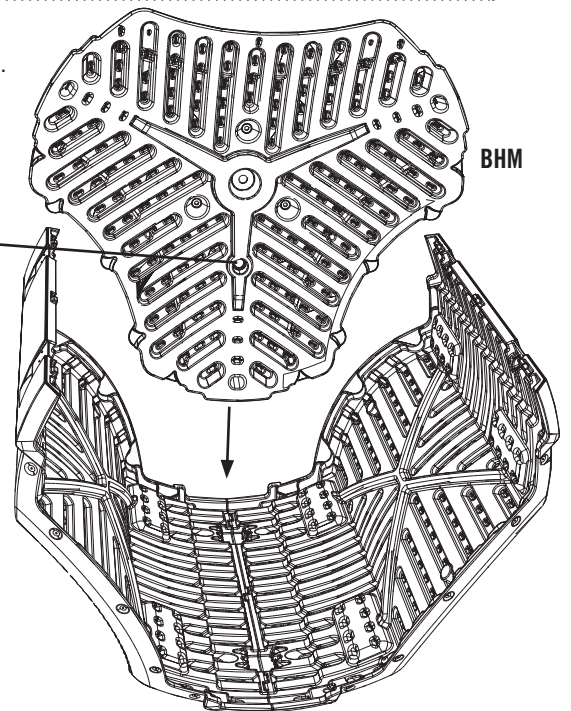

BHM



Note: The End Panel (BHM) fits just on the inside of the Front Panels.



TOOLS AND HARDWARE REQUIRED FOR THIS PAGE

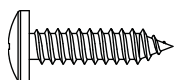
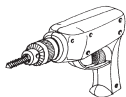

ADW (x10)

SEC 1

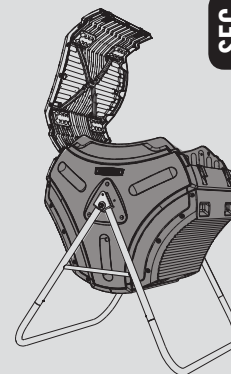

1.

SEC

1.7

2 ADULTS REQUIRED FOR THIS STEP

While one adult holds the assembly together, use an electric drill to insert ten (10) #10 x 3/4" Phillips Pan-Head Screws (ADW) through the holes you just drilled until the heads of the Screws are flush with the End Panel.

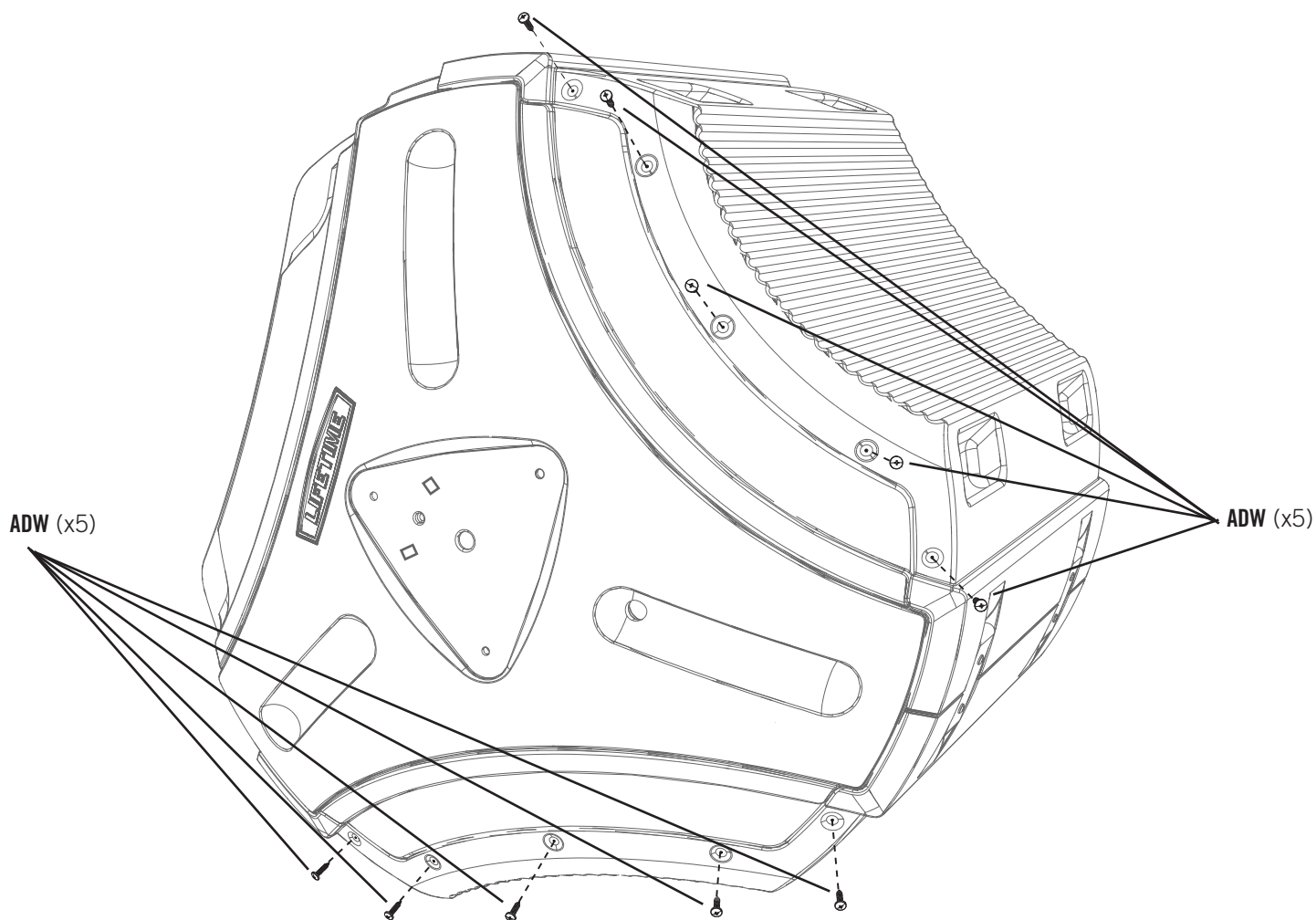

! Note: It's OK if the Screws (ADW) spin freely at this point. Don't worry about stripping the plastic.

1.



TOOLS AND HARDWARE REQUIRED FOR THIS PAGE



NO HARDWARE REQUIRED FOR THIS PAGE

SEC 1

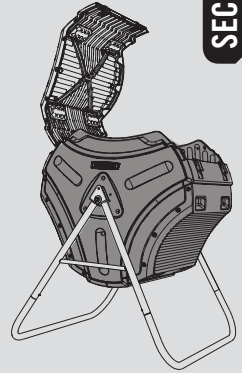

SEC 1.8

Insert the **Ventilation Tube (BHQ)** into the socket in the End Panel as shown. Orient the second **End Panel (BHM)** as shown and slide it down into position between the Front Panels. Ensure the other end of the Ventilation Tube fits in the socket of this End Panel.

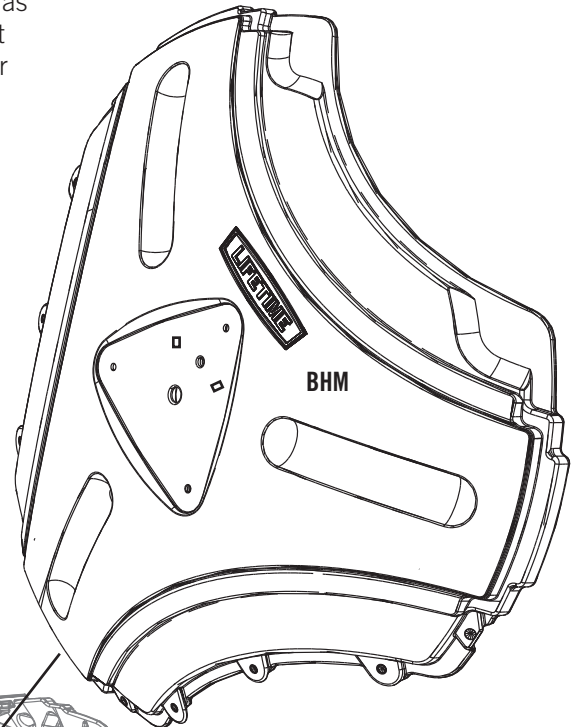

Note: Ensure the socket for the Ventilation Tube points downward.

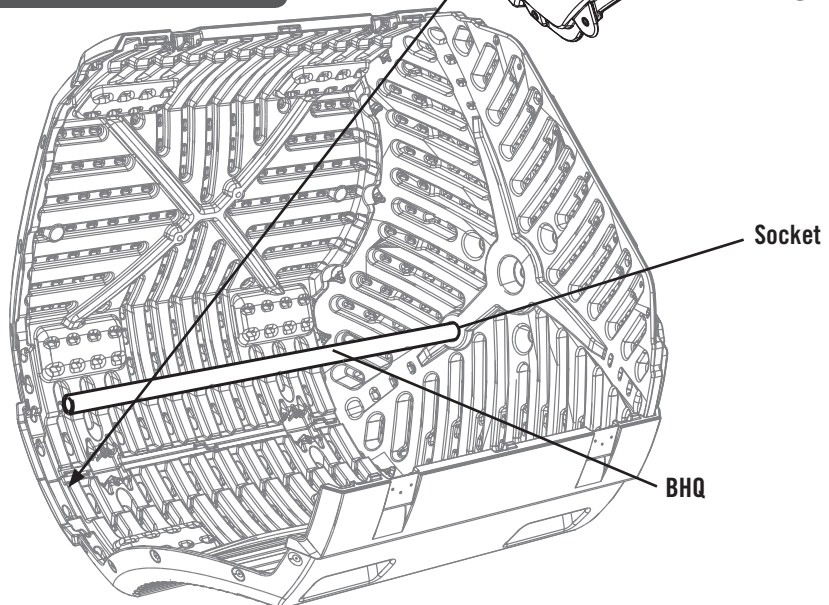

Note: The End Panel (BHM) fits just on the inside of the Front Panels.



TOOLS AND HARDWARE REQUIRED FOR THIS PAGE

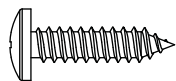
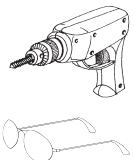

ADW (x10)

SEC 1

1.

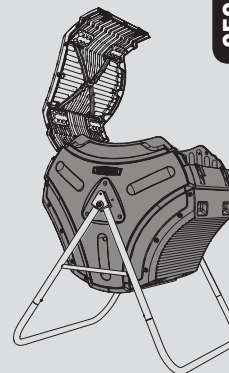

SEC

1.9

While one adult holds the assembly together, use an electric drill, insert ten (10) #10 x 3/4" Phillips Pan-Head Screws (ADW) through the holes you drilled in Step 1.5 until the heads of the Screws are flush with the End Panel.

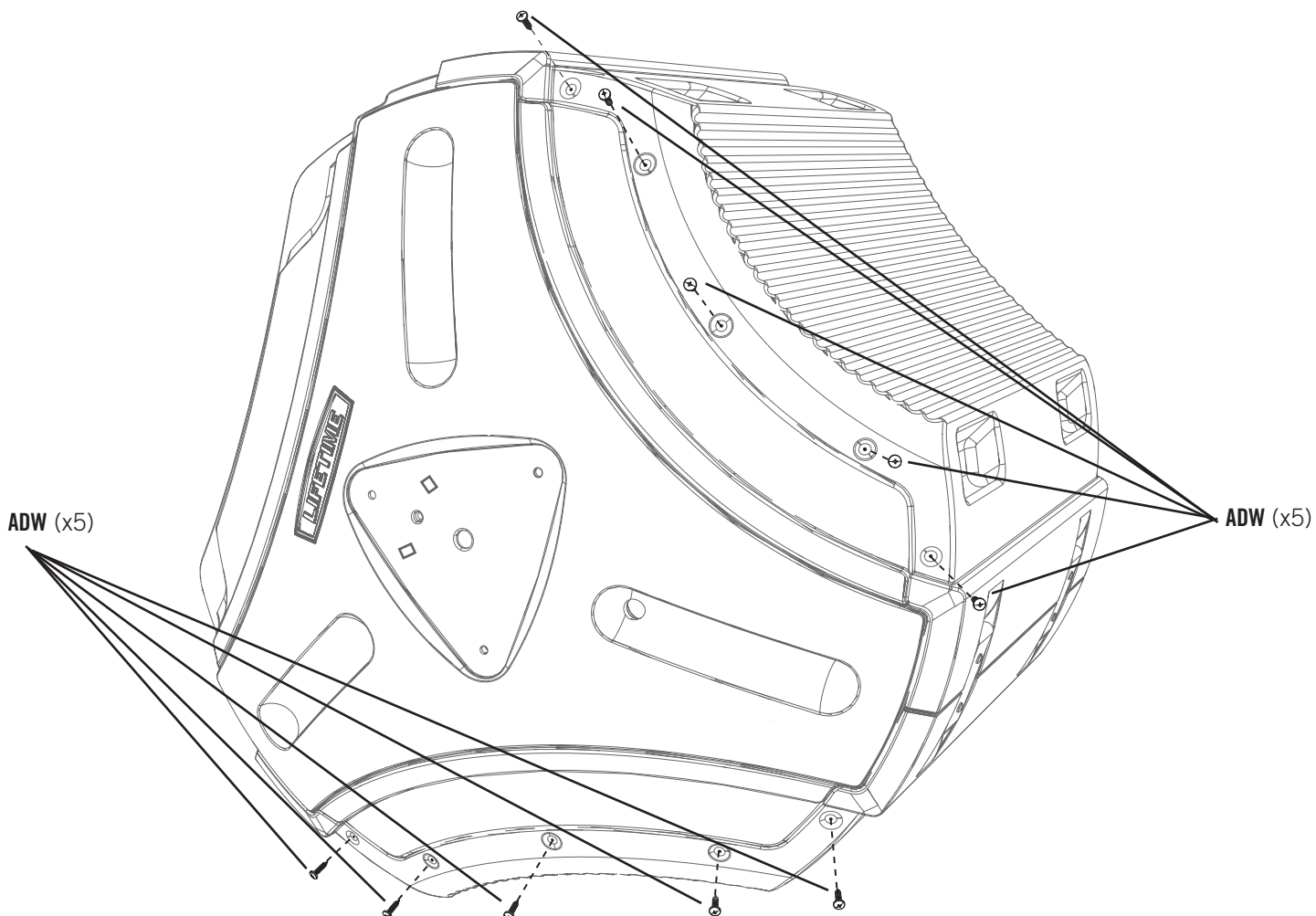

Note: It's OK if the Screws (ADW) spin freely at this point. Don't worry about stripping the plastic.

1.



TOOLS AND HARDWARE REQUIRED FOR THIS PAGE

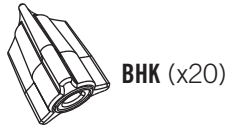
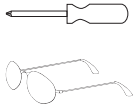

BHK (x20)

SEC 1

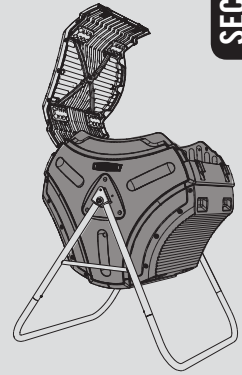

SEC

1.10

Place a **Plastic Nut (BHK)** over the end of a Screw and, using a screwdriver, tighten the Screws manually until the Plastic Nut is Flush against the Panel. Repeat for all Screws. Do not overtighten. **Repeat this step for the other End Panel.**

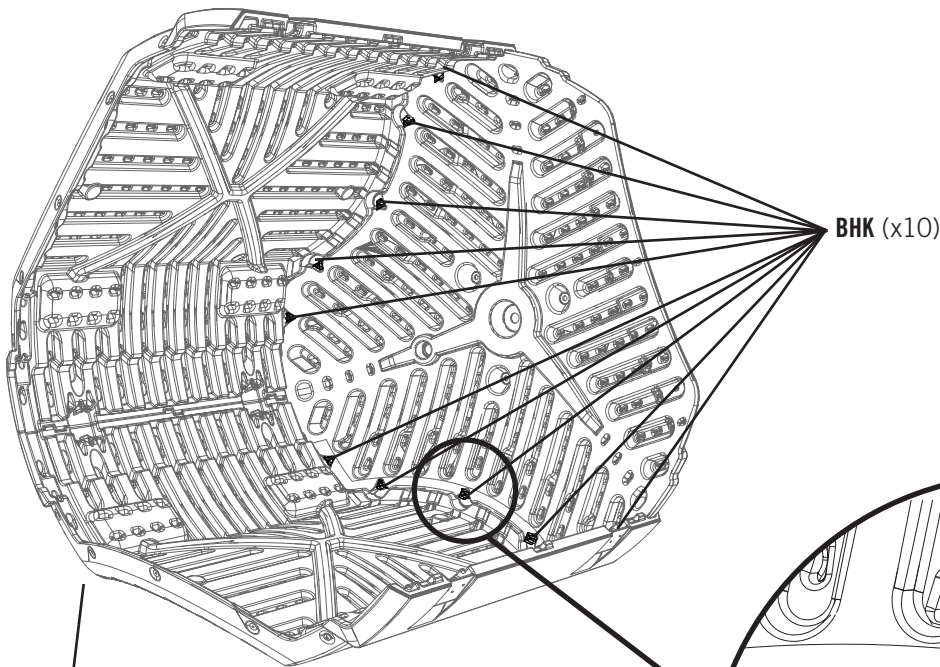

BHK (x10)

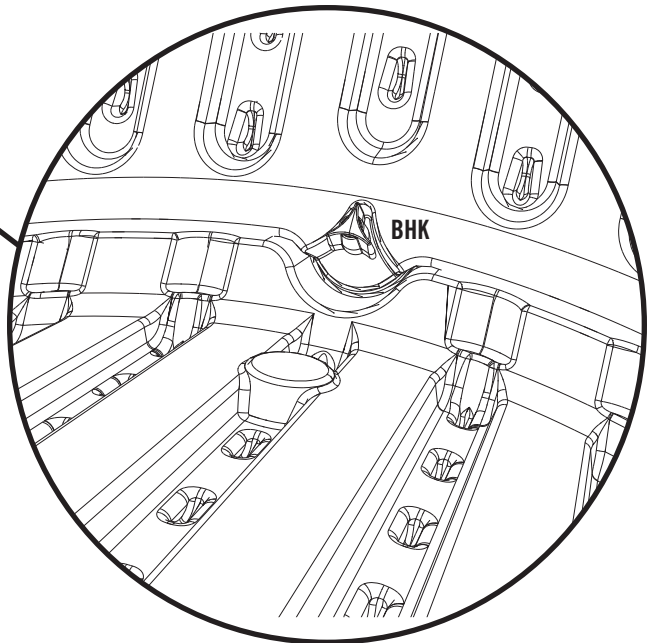

BHK



Note: End Panel removed to show detail.



Note: Tighten the Screws (ADW) into the Plastic Nuts (BHK) with a screwdriver only. Do not overtighten.



TOOLS AND HARDWARE REQUIRED FOR THIS PAGE



1/2"

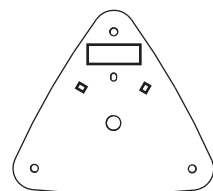

BSA (x2)

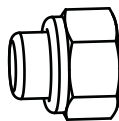

AAN (x6)

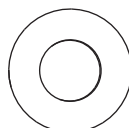

BHO (x6)

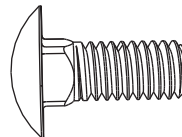

BIR (x6)

SEC 1

1.

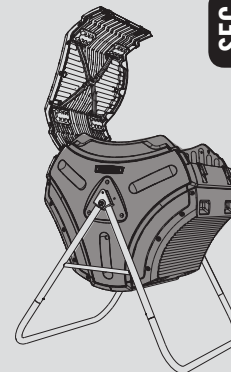

SEC

1.11

Orient a **Mounting End Plate (BSA)** so the holes in the Plate align with the holes in the End Panel as shown. Connect the Mounting End Plate to the End Panel using the required hardware. Tighten Cap Nuts securely. **Repeat this step for the opposite end of the Tumbler.**

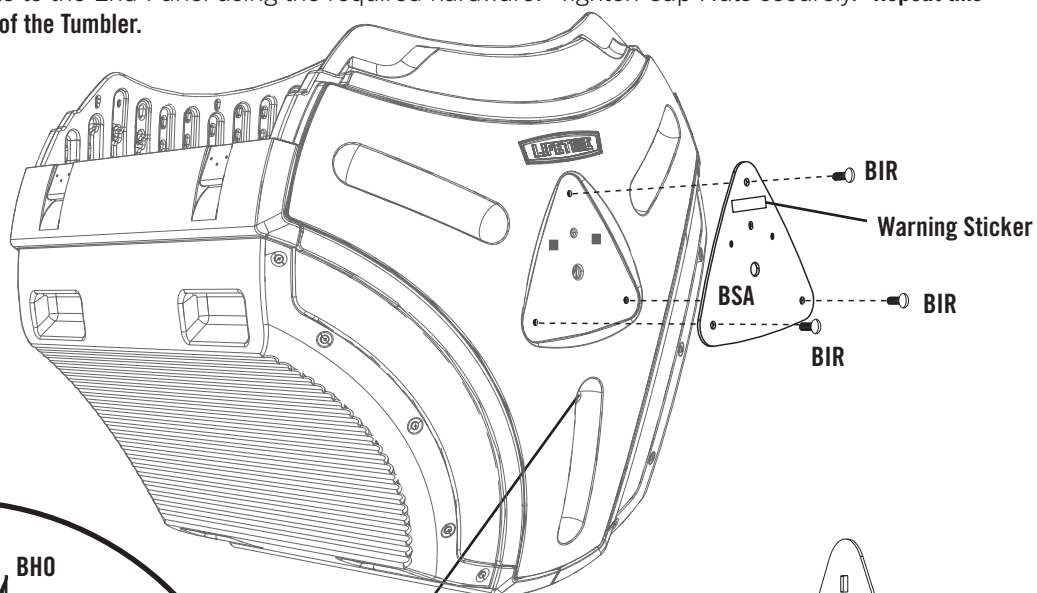

Ventilation Hole

The extruded end of the Mounting End Plate goes toward the Tumbler.

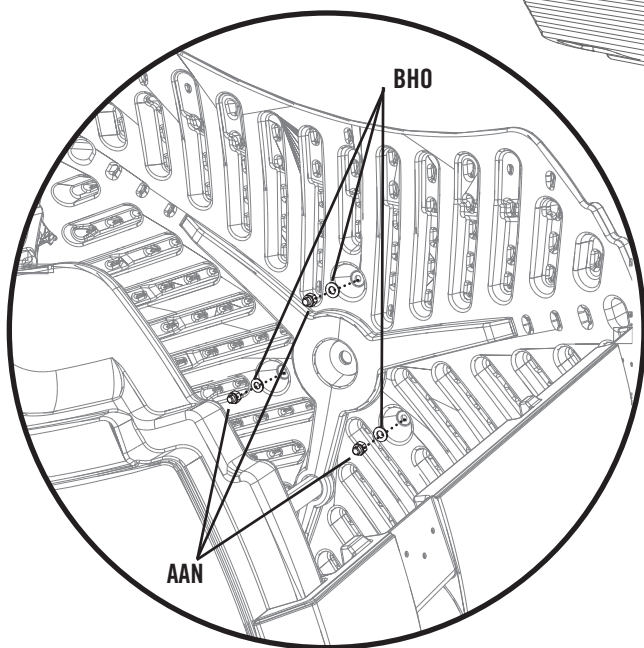

Interior View



WARNING

Do not overtighten the Cap Nut.